

ALMOHANDIS

Published By The Bahrain Society of Engineers

ISSUE

78

May
2024



BAHRAIN
SOCIETY OF
ENGINEERS



With a kind presence of
**His Excellency
Shaikh Khalid bin Abdulla
Al Khalifa**

Deputy Prime Minister
Kingdom of Bahrain



11 - 13 February 2025

A Journey with an Engineer:

**His Excellency the Engineer
Ebrahim bin Hassan Al Hawaj**
Minister of Works

"I believe that Bahraini engineers have
the ability to impress and excel"



**Success story of
Aqari**

A remarkable milestone in the
development of real estate sector
in the Kingdom of Bahrain

► **Journal Board:**

Dr. Isa Salman Qamber

Eng. Ahmed Hamad Al Wahoush

Eng. Jaffar Mohammed Ali

Eng. Ebrahim Ali Al Burshaid

Eng. Ayaa Shawqi

Editor-in-Chief

Managing Editor

Member

Member

Member

► **Media Officer:**

Hussain Ismail

► **Designing by:**

Ali Mulla

Published by:



**BAHRAIN
SOCIETY OF
ENGINEERS**

P.O. Box: 835, Manama

Kingdom of Bahrain

Email: mohandis@bse.bh

Website: www.bse.bh

Please send your articles to the
Bahrain Society of Engineers.

Bahrain Society of Engineers

Tel: +973 1772 7100

Fax: +973 1782 7475



bsemohandis

The Bahrain Society of Engineers
is not responsible for opinions
published in «ALMOHANDIS».

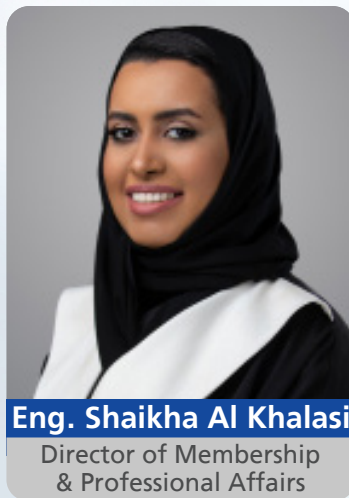
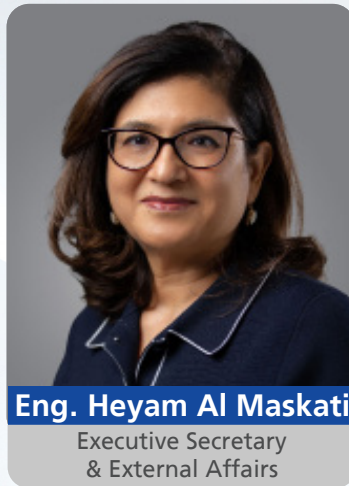

In this Issue

A Journey with an Engineer



8

A Journey with an Engineer:
**His Excellency
The Engineer
Ebrahim bin
Hassan Al Hawaj**
Minister of Works

Articles

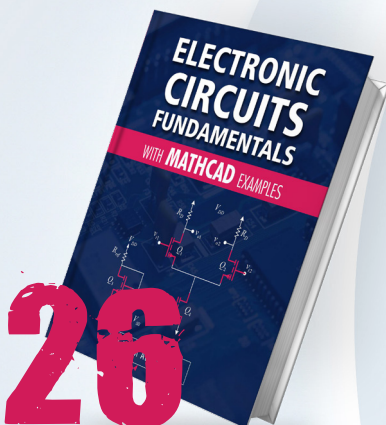

26

Book's review...
«**ELECTRONIC CIRCUITS
FUNDAMENTALS**»

Dr. Abdul Imam Al Sammak

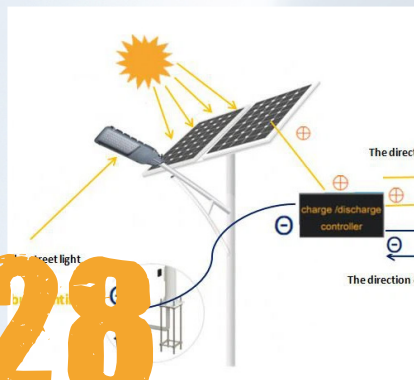

28

**From Oil to Sunshine: Battery
Energy Storage Lights the Way**

Eng. Khalid Qarooni

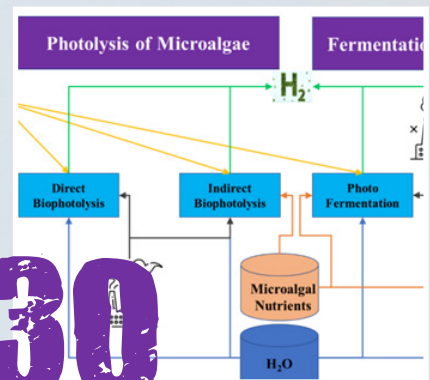

30

**Biohydrogen from Microalgae:
Sustainable Future for Clean
Energy Demand**

Eng. Dr. S. M. Zakir Hossain

Profile

20



Aqari Data Bank:

Aqari platform presents accurate, reliable and updated information on interactive maps and 3D visualization in a manner that serves a vast number of decision-makers, starting from individuals and ending with professionals in this field, together with government agencies and private sector's real estate companies.

Students Projects



32

Drone (Octocopter)



33

Smart Shopping Basket

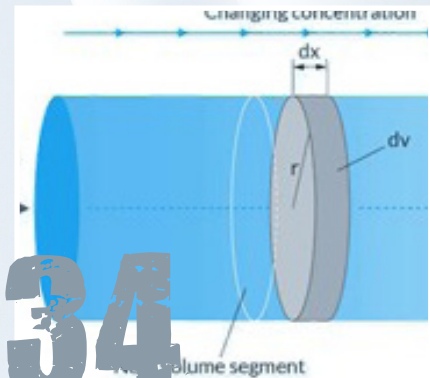

34

Simulation, Optimization, and Control of Methanol Production using Four Different Configurations

**Dr. Isa Qamber**

Technical innovations are accelerating in our modern era compared to previous times, and our relationship with keeping pace with technologies has a much deeper history than it seems. This means that modern technical development presents rapid transitional stages that transform and change according to what the current era and the society in which we live require. Modern examples of these technological transformations include infrastructure, user practices, industrial networks, and other transformations. Therefore, to use technologies, they must be linked to professional societies to meet specific needs that serve community from a technical and non-technical standpoint. Therefore, the Bahrain Society of Engineers took it upon itself to disseminate technical developments through *Almohandis* magazine, and through

conferences and professional workshops. Thus, technology can be defined as the tool that was invented. Among these techniques, some of them will be highlighted in this issue of the engineer's publications.

Through the issuance of this issue, major tasks of our ancient society were achieved, which took upon itself the diversity of cultures by meeting engineers who provide services to our engineering community. This was done through an interview with *Almohandis* magazine with His Excellency Engineer minister Ebrahim bin Hassan Al Hawaj, the Minister of Works in the Kingdom of Bahrain, where His Excellency rose through the career ladder until he reached the position of Minister of Works, and His Excellency's contribution is clear through the meeting with *Almohandis* magazine. It was highlighted that he grew up in a family that valued science. He completed his university studies as a civil engineer. His Excellency also touched on the role of the Bahrain Society of Engineers in enhancing professional and technical standards among engineers in our beloved Kingdom.

After that, we moved to the success story of the "Aqari" platform, which is considered a prominent landmark that sought to develop the real estate sector in the Kingdom of Bahrain. This institution is considered the main source of accurate and documented real estate information in the Kingdom of Bahrain. The Real Estate Information Bank "Aqari" was established, and this data bank represents a fundamental shift in how real estate data and information are dealt with in the Kingdom of Bahrain. This project supports the achievement of the Kingdom's strategic goals. This platform provides many important data that serve the real estate market and its dealers, which were explained in this issue of *Almohandis*. We also cannot forget that artificial intelligence (AI) plays a pivotal role in this platform. Through this, this platform is an inspiring success story.

The Electricity and Water Authority then proceeded to shed light on the most important aspects of its implementation of the National Renewable Energy Plan. From this standpoint, ensuring the renewal of energy and its reliance on its sources is one of the first priorities of the sustainable plan. It has briefly reviewed what has been implemented to date by the Authority. The implementation policy aims to increase the share of renewable energy resources by 5% by 2025 until it reaches 20% by 2035. The Authority has been keen, since the first day of the launch of the initiative, to give engineering cadres a decisive role in implementing the initiative, as Bahraini engineers contribute to the design of Implementing and following up on the implementation of the plan in the Authority.

To improve efficiency and achieve the Electricity and Water Authority's mission of providing a reliable, high-quality supply of water for the purpose of sustainable development in the Kingdom of Bahrain, the Authority has initiated its mission to reduce non-revenue water. Alleviating water scarcity is consistent with the overall Bahrain Vision 2030. The Electricity and Water Authority is already participating in many projects related to new technologies and tools that contribute to detecting, locating, and correcting leaks. There are stages monitored and identified for project implementation. There is also a wide range of modern technologies being tested to achieve this. The Authority also did not forget to train Bahraini engineers to contribute and participate in this mission that serves the Kingdom.

Among the publications that were chosen was the book of Dr. A.Imam Al-Sammak, where the title of the book is "Electronic Circuits Fundamentals," which is an academic book that can be taught in the universities in English language. From the title, it can be seen that the book teaches the student the required basics for electronic circuits, and students in bachelor's programs in electrical and electronic engineering that can also be obtained from this book.

The issue of small nuclear reactors and opportunities for integrating nuclear energy into the energy mix in the Kingdom

of Bahrain was addressed through an article by Dr. Mohamed Bin Shams. In his article, he touched on the production of electricity using nuclear energy, as the cost of nuclear energy ranges between \$117 and \$155 per megawatt hour. Despite the attractiveness of small nuclear reactors, there are still problematic aspects and negatives that must be addressed related to licenses and security procedures in eventual emergencies.

Engineer Khaled Qarouni then deals with the role of battery energy storage systems in the Middle East. Battery energy storage systems help mitigate the challenge of intermittent power, ensuring consistent power supply and grid stability. This highlights the growing importance of this technology in battery energy storage systems, which is a vital tool in reducing the risks associated with energy constraints and ensuring a smooth transition to renewable energy in the Middle East region. Storage systems contribute to the stability of the electricity grid. It is not secret to us that engineer Khaled Qarouni touched on the topic in the English side of Al Mohandis magazine.

Dr. S. M. Zakir Hossain, from department of Chemical Engineering, University of Bahrain wrote his article entitled Biohydrogen from Microalgae: Sustainable Future for Clean Energy Demand. He talked in his article that biohydrogen or hydrogen fuel has emerged to replace conventional fossil fuel as a promising renewable and green energy due to its non-polluting nature and high energy efficiency. Biohydrogen from microalgae is a potential alternative resource for hydrogen production. It is a clean technology that consumes CO₂ and is a renewable, cost-effective process. Alternative renewable and clean sources of hydrogen are always needed to meet the increasing global energy demand for the future and simultaneously suppress CO₂ emissions.

Since the coming the twenty sixth Gulf Engineering Forum will be hosted by our society (BSE) in our beloved Kingdom of Bahrain, so in this critical decade, and considering the pursuit of climate action, it is crucial that efforts be combined with realistic and ambitious solutions to address such issues related to climate action. Therefore, with the Gulf region's extreme heat and limited water supplies, climate change is a particularly pressing issue that must be addressed. This means that the Gulf region has a long history of being a leader in the energy and environmental industries, offering a wide range of business prospects as well as practical answers to global issues that researchers are trying to raise and propose solutions to the addressed problems.

In appreciation of the Bahrain Society of Engineers, which took it upon itself to encourage and encourage teams that produce in engineering works, the (TESLA) microreactor team, which is made up of a group of students affiliated with the University of Bahrain, was honored by the society's president, Dr. Raida Al-Alawi, as qualified team to reach the Hackathon finals organized by the World Federation of Engineering Organizations (WFEO), in partnership with UNESCO and Engineers Without Borders International.

Then we shift to the projects of students at the University of Bahrain in the College of Engineering, where three projects were discussed. The first project was addressed, which was entitled "Drone (Ectocopter)." The main challenge that was addressed in this project was the creation of a drone. A locally customized standard drone frame was a practical and adaptable solution, with the design demonstrating the ingenuity of the student team who implemented it. The implementation of the integrated proportional derivative control system and flight tests demonstrated the stability of the drone.

The second project was entitled "Smart Shopping Basket." This project was designed to reflect the uniqueness of this basket, which is designed for shopping on the smart system, and was designed with a contactless self-checking system seamlessly integrated into its design. This project significantly reduces waiting times now of shopping and improves the overall shopping experience. This project succeeded in maintaining a balance between functionality and financial constraints. This project's use of the Arduino and cost-effective components played a key role in ensuring the success of the project while highlighting the importance of practical solutions in meeting budget challenges.

In addition, the third project, entitled "Simulation, Optimization, and Control of Methanol Production using Four Different Configurations", was addressed by improving methanol production processes and promoting a sustainable and clean environment using renewable energy sources. A sustainable alternative to traditional fossil fuels and a contributor to reducing greenhouse gas emissions. Simulation results indicate that the best design using five reactors (PFR) with Direct Quenching Technique is the chosen design that achieves high productivity. It was concluded from these studies that some variables, such as the temperature and pressure of syngas, play a major role in improving the profitability objective function, as the results show an increase in profit of \$4.8 million per year.



- "His Excellency Shaikh Khalid bin Abdulla Al Khalifa, the first teacher and supporter of Bahraini engineers".

His Excellency the Engineer Ebrahim bin Hassan Al Hawaj Minister of Works

The career of His Excellency Eng. Ebrahim bin Hassan Al Hawaj, Minister of Works, represents a role model for career progression and excellence, as he began his career as a trainee engineer at the Ministry of Works, Electricity and Water, and progressed until he reached the top of the ministry's pyramid, after his appointment as Minister of Works.

His Excellency the Minister of Work has more than 35 years of practical experience in engineering work, where he contributed his practical and professional experience to the development of infrastructure and public services, especially in the sewage sector.

His Excellency Eng. Ebrahim bin Hassan Al Hawaj contributed to many infrastructure projects during his work as an engineer in the Ministry of Works and an official in the sewage sector, and he had a prominent role in the introduction of Hypex technology, which represents a qualitative leap in the operation of the sewage system, in addition to being part of the team that worked on restructuring the Ministry of Works.

His Excellency Eng. Ebrahim bin Hassan Al Hawaj stressed that the Bahrain Society of Engineers has contributed during its journey to supporting the level of engineering work in the public and private sectors, in addition to raising the efficiency of the national engineer and making him an option in working in the two sectors, and promoting this professional sector in a way that contributes to achieving national goals and supporting the comprehensive development process in the Kingdom of Bahrain.

"Al Mohandis" magazine conducted an interview with His Excellency Eng. Ebrahim bin Hassan Al Hawaj, Minister of Works, to learn about aspects of his career and his busy engineering career.

Details of the meeting are as follows:



His Majesty King Hamad bin Isa Al Khalifa, the great King of the country, may God preserve him, honors the His Excellency Eng. Ebrahim bin Hassan Al Hawaj with the Badge of Honor of Efficiency coinciding with the country's celebrations of the National Days in December 2018.

First of all, we would like to know about the upbringing of His Excellency Eng. Ebrahim bin Hassan Al Hawaj, and the schools in which he studied up to the university level?

Thank you for your attention.

I grew up in a family that valued education, which formed my compass towards a commitment to academic excellence from a young age. I started my education in Manama Public Schools I studied at the primary stage at Imam Ali Primary School for Boys, in the early seventies, then I moved to Abu Bakr Al-Siddiq Preparatory School, after that, I moved to pursue my secondary education at Hoorah School in the secondary stage, which is now Ahmed Al-Omran Secondary School, where I delved deeper into the

fields of science and technology and is also known for its focus on the excellence and outputs of its students. The learning environment there was challenging but motivating, and it helped me develop my passion for engineering, paving the way for me to enter the engineering field with confidence and knowledge. I graduated in high school in 1980. I reached the university level, and in the same year I received a scholarship from the Ministry of Education and the mission was provided by the Ministry of Works.

"I received a scholarship from the Ministry of Works to study engineering and entered the ministry as a trainee engineer"



His Royal Highness Prince Salman bin Hamad Al Khalifa, His Royal Highness Prince Salman bin Hamad Al Khalifa and Prime Minister, may God protect him, during his visit to one of the projects implemented by the Ministry of Works in the Northern Governorate, and His Excellency Eng. Ebrahim bin Hassan Al Hawaj appears listening to the directives of His Royal Highness Prince Salman bin Hamad Al Khalifa.

**What motivated you to study engineering?
Do we know a little about the atmosphere
and years of your university studies?**

Thanks for asking this question.

Engineering for me was not just an academic choice, it was a passion that has been in me since childhood. I've always been fascinated by how things work and how they can be optimized for the best possible performance. It is this natural curiosity that led me to study engineering, as I wanted to be part of a community that contributes to the development of solutions to contemporary challenges.

As for the atmosphere of my university years, it was full of challenges and achievements. University life was rich in activities and projects that promoted practical and theoretical understanding. We had the opportunity to work on realistic projects thanks to the university's collaboration with leading engineering companies and institutions in the USA. Each project was an opportunity to apply what we learned in the classroom and turn theories into concrete solutions. These experiences have been instrumental in shaping my skills and understanding of the engineering

profession, and I am grateful for all those years spent fulfilling this passion.

During the summer period and during the study, we return to work as trainees in the Ministry of Works, where I worked in sewage sector projects, and at that time Engineer Majid Jawad Al-Jishi, may Allah have mercy on him, was the Minister.

Was His Excellency Eng. Ebrahim bin Hassan Al Hawaj influenced by an engineering personality that influenced him to choose to study engineering and engineering specialization?

Interest in scientific aspects such as mathematics, chemistry, and physics tends students to study engineering, but in fact, the personal and professional influence of a number of engineers has played a role in confirming my decision to enter this field and choose it as a career. Figures such as Eng. Zubaida Al Hashemi, Eng. Ali Murad, and my friend His Excellency Engineer Essam bin Abdulla Khalaf, former Minister of Works, Municipal Affairs and Urban Planning, who has always been my companion in my career,

have provided me with vivid examples of dedication and innovation in engineering, in fact the way they approach engineering challenges and develop solutions has been inspiring. To me.

This combination of scientific theories and their practical and effective application made me realize the importance of engineering in improving the quality of life and advancing human progress.

I can also say that I learned and was impressed by the Bahraini workers we worked with on the ground, who worked with dedication and dedication to serve the country and citizens.

Those were a political motives for me, and since then I have been trying to leave a similar mark in this field.

Readers of (Al Mohandis) magazine would like to learn about your engineering career and your beginnings in the engineering field, leading to your obtaining the royal confidence by appointing you as Minister of Works?

I would like to thank you and the readers of Al-Mohandis magazine for your interest in my career. My journey in the field of engineering began in the corridors of the university where I gained my academic degree in civil engineering during that period, I learned the importance of precision, innovation, and teamwork, principles that formed the basis of my professional approach later.

Upon graduation, I was involved in a variety of large engineering projects that had a significant impact on infrastructure development. I moved between several roles, from field engineer to project manager, where each role required applying my technical knowledge and enhancing my management capabilities. Every step in my career has taught me a new lesson in how to achieve excellence and effectiveness in leading engineering projects.

I am deeply grateful for the royal trust placed in me by appointing me as Minister of Works, and I am fully aware that this appointment not only recognises my contributions in the past, but also places a great

"Engineering workforce in the Ministry of Works represent the basis of various infrastructure development projects"

responsibility on me and gives me an exceptional opportunity to contribute more and deeper to the development of the national infrastructure and drive progress in the Kingdom of Bahrain.

Assuming this position reinforces my motivation to work with unrelenting effort to achieve a comprehensive national vision aimed at promoting the well-being and sustainable development of our country. I take this responsibility very seriously, recognizing that the role I occupy is highly trusted by the leadership and citizens.

I would also like to express my deep appreciation to everyone who supported and encouraged me in my engineering career. My commitment to work wholeheartedly and strive to take the Ministry of Works to new heights is a pledge I make, inspired by the team spirit and joint work that characterizes my colleagues and assistants, I look forward to moving forward towards achieving our national aspirations with confidence and effectiveness.

As I mentioned, my relationship with the Ministry began in 1980 with a mission from the Ministry of Education provided by the Ministry of Works, and after graduating in 1986, I started in the Ministry as a trainee engineer, and I started in the Department of Public Health Engineering, which is the department for sanitation, as the sanitation service is related to public health.

During the internship, we had to move to the entire departments of the ministry in roads, sanitation and materials engineering, and three years later I was hired as an engineer who supervised the contractors executing the projects.

After that, I became a senior engineer at the beginning of the nineties, until I became the head of the engineering services department in 2000,



His Excellency Shaikh Khalid bin Abdulla Al Khalifa, His Excellency the Deputy Prime Minister Shaikh Khalid bin Abdulla Al Khalifa receives a memorial gift from His Excellency Eng. Ebrahim bin Hassan Al Hawaj, Minister of Works, during his visit to the Ministry of Works building in Hooraa in 2023.

and in 2006 I was appointed director of the Sewage Operation and Maintenance Department under the former minister, Engineer Fahmi Al Jowder, and in 2015 I was appointed as an assistant undersecretary for technical services, then I returned again to the sewage sector as an assistant undersecretary in 2020, then I was appointed as an undersecretary for agriculture and marine resources in 2021, and during 2022 I was appointed Minister of Works.

During the period of former Minister Fahmi Al-Jowder, I was part of the ministry's restructuring team and the ministry's strategy team, and these experiences affected my work experience.

As an engineer and minister, how do you see the importance and role of engineering in adapting the management of this large ministry concerned with dozens of large projects in the country?

This important inquiry touches the essence of my job as an engineer and minister. It is well known that engineering is not limited to design and construction only, but extends to the effective management of large projects that belong to the Ministry. In this context, engineering principles help to provide a systematic and scientific approach to dealing with

significant challenges, enabling the highest levels of efficiency and effectiveness.

As an engineer and minister, I use these principles to ensure meticulous project planning, relying on detailed technical analysis that allows for a deeper understanding of the multiple aspects of the project from costs, timelines, and resource management. This approach enables us to develop effective strategies for the implementation and continuous evaluation of operations, ensuring high quality and compliance with environmental and regulatory standards.

Innovation in engineering enables us to adopt advanced building technologies and use new materials that enhance the durability and efficiency of infrastructure. Investing in these technologies directly contributes to reducing costs and improving long-term performance.

I would also like to emphasize that engineering is not only a tool for construction, but a basis for promoting sustainable development and supporting the economic and social prosperity of the Kingdom. I ask Almighty God to endure and unwavering the Ministry's commitment under my leadership to achieve these goals, through which we implement projects that meet the current and future needs of our citizens with the highest standards of safety and quality.



His Excellency Engineer Fahmi bin Ali Al Jowder, former Minister of Works, in a discussion with His Excellency Eng. Ebrahim bin Hassan Al Hawaj, Minister of Works, who was then Director of the Sanitation Operation and Maintenance Department at the ministry, in one of the workshops to prepare the ministry's strategic plan.

Here, the strategic and practical role of engineering in the management and implementation of major projects within the Ministry emerges, with a focus on innovation and sustainability for these projects.

How do you assess the role played by the Bahrain Society of Engineers in the engineering sector in the Kingdom of Bahrain? That is, how do you see the work of the association in performing the role entrusted to it as a specialized professional association in the engineering sector?

A question that already highlights the role of the Bahrain Society of Engineers as a pivotal institution in the engineering sector in the Kingdom of Bahrain. In my view, the association plays a very important role in promoting professional and technical standards among engineers in the country. It also contributes to the development of skills and provides the necessary resources for engineers to improve their performance.

The association plays an active role in linking engineers with various industrial and educational bodies, which helps to exchange knowledge and experiences, and provides training opportunities and continuous professional development. This approach enhances the capabilities of engineers to adapt to technological

changes and new challenges in the sector.

In addition, the association plays an important role in representing engineers before government and private entities, and acts as a voice for engineers on important issues affecting the profession and the sector as a whole. Its impact extends to the policies governing engineering and professional standards in the country, ensuring that Bahrain's engineering practices are of a high level of professionalism and ethics.

In the end, it can be said that the Bahrain Society of Engineers has been remarkably successful in performing its role as a professional specialized association that supports and advances the engineering sector in Bahrain, and I highly appreciate its efforts in this regard.

Here, I would like to express my high appreciation for the role of the association and for its impact in the engineering sector.

How do you assess the role of the engineering sector in the development and urban renaissance in the Kingdom of Bahrain?



His Excellency Engineer Esam bin Abdulla Khalaf, former Minister of Works, and His Excellency Eng. Ebrahim bin Hassan Al Hawaj, Assistant Undersecretary for Technical Services at the Ministry of Works, Municipal Affairs and Urban Planning at the time, during the follow-up of one of the projects implemented by the ministry.

Shedding light on the vital role of the engineering sector in the development and urban development in the Kingdom of Bahrain. The engineering sector is considered the heart of the country's development renaissance, playing an essential role in the design and construction of key infrastructure that includes roads, bridges, health facilities, educational institutions, and industrial facilities. These projects are the backbone of any economic and social progress, and play a pivotal role in improving the quality of life for citizens.

Through its commitment to excellence and innovation, Bahrain's engineering sector is actively contributing to the implementation of the National Vision for Sustainable Development. This is done by applying the latest technologies and international standards in its projects, which leads to the creation of innovative solutions that ensure efficient and effective use of resources and reduce environmental impacts.

In addition, the engineering sector plays a major role in the national economy by supporting the diversification of sources of income. Engineering innovations and infrastructure improvements are also contributing to attracting foreign investment and boosting other economic sectors such as tourism and trade.

The engineering sector also plays an educational and awareness role through the development of engineering education programs and continuous training, which ensures the preparation of a new generation of distinguished engineers who are able to face future challenges and contribute to the continuity of development and growth.

The engineering sector's commitment to excellence and innovation not only reinforces Bahrain's position as a leading regional and global engineering hub, but also establishes a prosperous future for all citizens.

He highlighted the importance of the engineering sector in the development and modernization of infrastructure and its role in promoting economic growth and sustainable development in the Kingdom of Bahrain.

What hobbies does His Excellency Eng. Ebrahim bin Hassan Al Hawaj love and practice?

This personal question gives me the opportunity to share some aspects of my life outside of work. I consider that work-life balance is essential for success, which is why I make sure to make time for my hobbies that help me recharge my energies and enhance my creativity.

One of the hobbies that I enjoy a lot is reading, especially in the fields of engineering and science, and it is possible to be considered a new reader of the financial and economic fields, and I always long for travel, which also gives me time to think and reflect away from the pressures of work and provides me with opportunities to discover new horizons and deepen my understanding of the world around me.

In addition, I love exploring different food styles and I find this exploration a way to try something new, which allows me to share quality time with family and friends.

These hobbies are not only a means of rest and relaxation, but they also enhance my personal and professional skills by developing patience, focus and perseverance and contribute to refining my personality and enhancing my overall abilities.

Has your job and engineering major influenced your children's educational path? How?

This question arises an important aspect of personal life. Indeed, my engineering major and career have had a noticeable impact on my children's educational path. As an engineer, I have always had a strong commitment to the importance of science and education, and this is something I have instilled in my

"The engineering sector is one of the active and main sectors in the process of development and construction"

children from a young age.

Exposure to engineering projects and discussions about engineering challenges and solutions at home helped develop my children's curiosity and interest in science and technology. This scientifically stimulating environment positively influenced their educational choices, as some chose the engineering field, for example, my eldest son works in the field of cost engineering in the private sector, while the youngest son is studying medical device engineering.

Yes, my job and engineering major played a big role in shaping my children's perspectives and educational choices.

Although I stress that the choice of academic and professional specialization comes based on the choice of children and their desire, I believe that the relationship between the professional life of the engineer and its impact on the educational and personal choices of children, has highlighted, praise be to God, the educational method and the positive impact of the scientific environment at home.

What are the most important honors in your career? or community?

Beautiful are the moments of sharing special pauses in my professional and community career. Throughout my career, I have had the privilege of receiving several honors that express recognition for my efforts, but some of them hold a special place for me.

Honoring me with the Order of Efficiency from His Majesty the King, which represents a badge of pride for every Bahraini, represents a motivation and a mandate to continue giving and working with determination to serve this generous country. It was a defining moment in my career. This accommodation honoured me for my contributions to the development



His Excellency Engineer Essam bin Abdulla Khalaf, former Minister of Works, Municipal Affairs and Urban Planning, future His Excellency Eng. Ebrahim bin Hassan Al Hawaj, Director of the Sanitary Engineering Planning & Projects Directorate at the Ministry at the time, and Eng. Zubaida Al Hashemi, Director of the Sanitary Engineering Planning & Projects Directorate.

of national infrastructure, and it is an affirmation of the importance of hard work and commitment to high standards in the engineering profession.

What are the most prominent achievements that His Excellency Eng. Ebrahim bin Hassan Al Hawaj believes he has achieved in his life? On a personal or functional level?

This question invites me to reflect on my professional and personal career, which requires a balance between the professional and professional side and from my point of view, achievements are represented not only in visible successes, but also in continuous work and continuous development that is achieved throughout life.

On a personal level, I consider creating a cohesive and supportive family as one of my most important achievements. The ability to raise children with good morals and their commitment to the importance of

science and learning is what makes me deeply proud.

Professionally, I consider my role in implementing and managing several large infrastructure projects that have tangible impacts on improving the quality of life for citizens to be one of my most prominent achievements. These projects have not only contributed to economic development but also to the strengthening of the country's basic infrastructure.

I also see the development of engineering policies and new technologies that reflect our commitment to environmental sustainability as a major achievement. We have been able to adopt advanced standards that contribute to preserving the environment and improving resource efficiency, which is a big step towards a more sustainable future.

All these achievements, whether personal or professional, give me the motivation to continue working hard and giving to achieve further progress and contribute positively to society.

I believe that achievement is greater when it is reflected at the national level, and within the same team.

As Minister of Works and responsible for the implementation of many strategic and mega construction projects, what are the most important projects that have been completed in your ministry? Or that are under implementation?

Thank you for this question which gives us an opportunity to highlight some of the important achievements of the Ministry of Works. During my tenure, we have implemented several strategic projects that are the cornerstone of the national development plans aimed at improving infrastructure and promoting economic growth in the country.

Among the most prominent priority infrastructure projects that have been completed in various sectors of the ministry, represented in the roads sector, the sewage sector, and the buildings sector, during 2023.

In the roads sector, the Ministry has completed a number of traffic improvement projects, most notably the Al Fateh Street Development Project, which is one of the major strategic projects in the infrastructure sector, the expansion project of the Upper Jasra Interchange - Ramp No. 1, the development of Bridge 17 on um Al Saad Street south of Sitra Island, and the rehabilitation project of Sheikh Khalifa bin Salman Street.

The Ministry has also completed one of the important projects, which is the project of finding sustainable solutions for rainwater catchments in the Lawzi area.

The Ministry is currently working on implementing a number of strategic projects that contribute to facilitating traffic, including the Janabiya Street Development Project, the Al-Dair Street Development Project, the Sheikh Khalifa bin Salman Street Rehabilitation Project, the Construction of Roads leading to East Sitra City – Phase I, in addition to many other projects in various regions in the Kingdom.

In the sewage sector, the Ministry of Works has continued implementing projects to establish

Achievements within the team "Akbar" and this is what we are working on in the Ministry of Works"

sewage lines and networks, aiming to develop this vital sector, expand the service's beneficiaries, and ensure a healthy environment for all. One of the most important projects is the main line transporting sewage from Salmabad to the intersection of the E and F networks. Additionally, projects are being established in various areas to keep pace with urban and investment development in Bahrain.

The Ministry is implementing several strategic projects, including the expansion of the Tubli wastewater treatment plant, the main line project transporting wastewater from A'ali to Salmabad, and the transmission line project in the Zinj region.

The Ministry is also working within its plan to keep pace with urban expansion and provide a healthy and sound environment in establishing sewage networks in various regions, according to the Ministry's plan.

In the buildings sector, the Ministry has implemented and followed up on numerous strategic projects in coordination with various government agencies to support their programs and plans. The number of projects has reached 32, including the National Bank of Bahrain Multiple Sclerosis Center, the construction of several buildings, the Tubli sewage station, and the Sheikh Abdulla College of Islamic Studies.

Currently, work is underway on many projects to develop government buildings. Notable projects include the development of the Old Country Health Center, the expansion of the Kuwait Health Center in Karzakan, and the maintenance of several government schools, including historical schools, in cooperation with the Ministry of Education and the Bahrain Authority for Culture and Heritage.

These projects embody our commitment to improving infrastructure and enhancing the quality of service

"I believe that Bahraini engineers have the ability to impress and excel"

provided to every citizen and resident, ensuring a prosperous and sustainable future for all.

Given your extensive experience in engineering and administrative work, your career is full of impactful and memorable situations. Can you share some of these experiences with the readers of Al Mohandis magazine?

Of course, I am happy to share these important experiences with the readers of The Engineer. Interacting and working alongside leading figures such as His Royal Highness Prince Salman bin Hamad Al Khalifa, Crown Prince, provides invaluable opportunities for personal and professional development, especially in integrating political and engineering aspects in national projects.

A situation that profoundly impacted my understanding of combining engineering and politics was during the planning phase of a major infrastructure project. During Coordination Committee meetings, HRH the Prime Minister and His Royal Highness Prince Salman bin Hamad Al Khalifa, Crown Prince of the Kingdom, emphasized the importance of engineering plans considering the social and economic needs of local communities. This highlighted that success in engineering is measured not only by technical excellence but also by the extent to which these projects improve people's lives.

During the launch of Hazm Al Lawzi projects, His Royal Highness Prince Salman bin Hamad Al Khalifa stressed the need to develop international best practices in construction to ensure the sustainability of projects. There were in-depth discussions on how to employ engineering innovations to achieve national strategic goals. From this experience, I learned the importance of linking the strategic vision of political leadership with engineering applications to ensure effectiveness and efficiency.

I also cannot fail to stand on the extent to which I am influenced by His Excellency the Deputy Prime Minister Shaikh Khalid bin Abdulla Al Khalifa, this distinguished personality in government and engineering work, as he has experience and wisdom in managing infrastructure development projects, as he contributes to solving files in various infrastructure projects, whether in the sectors of works, electricity, water, and municipal projects, in addition to his permanent directives in rationalizing projects and finding appropriate solutions. Sponsor and follow-up of infrastructure development projects.

Everyone believes that His Excellency is considered the first teacher of engineers in Bahrain, in addition to gaining great administrative experience and wisdom in managing government work and the various files presented to him.

These attitudes and working alongside these two personalities taught me how to look at engineering not only as a science and technology, but as a tool to achieve sustainable development and meet the aspirations of the country and citizens.

The lessons learned from the His Royal Highness Prince Salman bin Hamad Al Khalifa and His Excellency the Deputy Prime Minister Shaikh Khalid bin Abdulla Al Khalifa always inspire me in striving to make the most of engineering projects to serve our national goals.

What impact did these attitudes have on you and have had a significant impact on your lives?

There are many experiences that I was influenced by, during the field work I was greatly influenced by the Bahraini workers who were working in infrastructure development projects, and they were an example of sincerity, altruism and selflessness, and I remember one of the workers who completed a service alone for a citizen in one of the sewage connection projects when I was a field engineer, provided that the citizen is not harmed more than the work near his home.

In addition to the situations I witnessed and the lessons I learned alongside leading figures such as the His Royal Highness Prince Salman bin Hamad Al

Khalifa and His Excellency the Deputy Prime Minister Shaikh Khalid bin Abdulla Al Khalifa, not only were they useful in my professional field as an engineer and minister, but also left a deep imprint on my personality and my approach to life.

One important effect of these positions was to enhance my understanding of the importance of strategic vision in leadership. You have learned how to plan and execute based on a clear vision that considers the long-term impact of decisions. This approach has not only enhanced my ability to manage large projects, but has also increased my ability to make informed decisions that ensure sustainable and inclusive success.

These attitudes have also had a significant impact on my commitment to giving the best to my community. By witnessing and experiencing how engineering projects can directly improve people's lives, I developed a deep sense of social responsibility. I have become more keen to ensure that all the projects we implement in the Ministry are not only technically successful, but also useful and for the benefit of the public. In addition, I realized the true value of leadership by example. I learned that an effective leader is one who can inspire, motivate, and guide their team to achieve goals that exceed expectations. This leadership vision fueled my interest in developing my leadership skills and fostering collaboration and innovation within my team.

Overall, these situations were not just fleeting moments in my career, but life lessons that shaped my outlook on work and life, and greatly influenced my approach as a leader and as an engineer committed to serving my country and community.

Perhaps our young engineers are eager for a directive or a word from the minister, is there a word you would direct to young engineers or those who are about to study engineering and specialize in it?

Of course, I am very happy to share some tips and guidance for our young engineers and students who are about to study this important and influential field.

Engineering is a noble profession that offers tremendous opportunities for creativity and innovation, and has a major role in shaping the future of our societies.

First, I would like to encourage all young people interested in engineering to commit to continuous learning. The world around us is changing rapidly, and the field of engineering is constantly evolving with the emergence of new technologies and innovative solutions to old and new problems. Curiosity and the desire to learn are the keys to success in this field.

Second, I recommend working on developing communication and teamwork skills. In engineering, the ability to communicate effectively with teams, clients, and other parties can be just as important as technical skills. Teamwork enhances your ability to successfully execute projects and opens up new avenues for innovation and professional advancement.

Third, I urge you to pay attention to the ethical and social aspects of engineering work. Engineering is not just an art calculation and design, it is also a work that affects people and the environment. Be engineers who consider the environmental and social impacts of their projects, and always strive to contribute to building a better world.

Finally, be brave in the face of challenges and don't be afraid to take the initiative and take risks for innovation. The road to success is full of obstacles, but with persistence and dedication, these challenges can be turned into opportunities for growth and learning.

I wish you all a bright future in the field of engineering, and to be ambassadors of this ancient profession, inspiring others and contributing to the progress and well-being of your communities.

"I was greatly influenced by the Bahraini workers who were working in infrastructure development projects, and they were an example of sincerity, altruism and selflessness"

Aqari

Data Bank



عقاري

بنك المعلومات

AQARI.RERA.GOV.BH

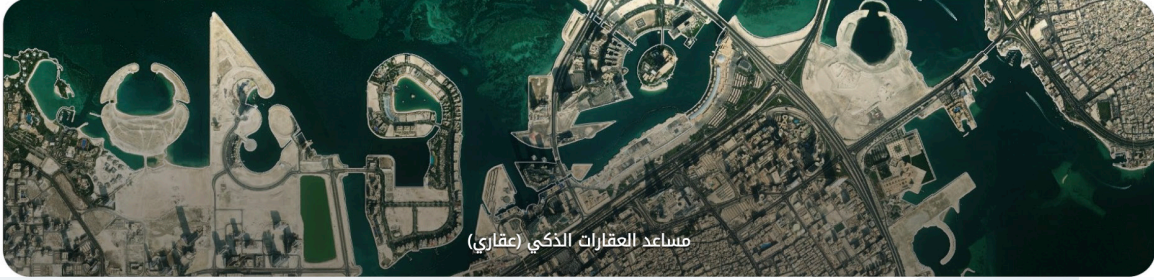
 ابدأ في استكشاف عقاري

Kingdom of Bahrain مملكة البحرين

 مؤسسة التنظيم العقاري
 Real Estate Regulatory Authority

Success story of "Aqari"

A remarkable milestone in the development of real estate sector in the Kingdom of Bahrain

Since 2019, the Real Estate Regulatory Authority commenced an ambitious journey to attain a radical transformation in the real estate field. This is reflected in the launch of the National Real Estate Data Bank (Aqari) being the primary source of real estate information in the Kingdom of Bahrain. Launched in 26 December 2023, it is the first of its kind project in the region. It is a part of an electronic organization services and is considered a substantial addition to the digital transformation of real estate transactions. It employs modern techniques such as artificial intelligence (AI) cloud computing and geographical information system.

"Aqari platform presents accurate, reliable and updated information on interactive maps in a manner that serves a vast number of decision-makers, starting from individuals and ending with professionals in this field, together with government agencies and private sector's real estate companies".

Importance of Aqari Platform

The Real Estate Data Bank (Aqari) is a substantial transformation in how to deal with the real estate information and data in the Kingdom of Bahrain. The significance of this project is represented in the following:

- Transparency and clearance: Aqari presents transparency in the real estate market through

accurate and updated information, which will contribute in increasing investors confidence and traders in the sector.

- Supporting decision makers: Aqari offers reliable and comprehensive data, on the basis of which the investors, developers and the government bodies may take sound decisions based on accurate market analysis.

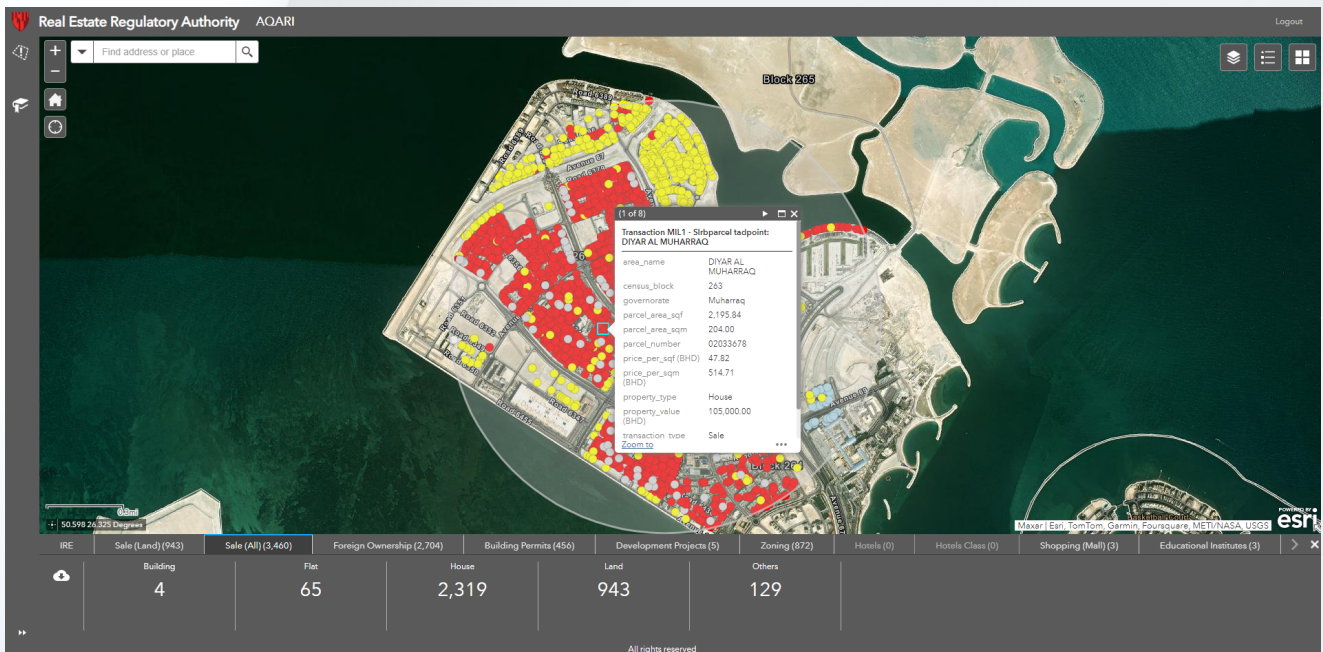

- Enhancing investment: Through provision of a clear vision of the real estate market trends, since Aqari supports creation of new investment opportunities within the sector, whether by local or international investors.
- Innovation and development: The Data Bank opens its doors in front of technological creativities in the real estate sector such as using AI and advance analysis for the sake of developing creative real estate services in future.

Platform's Objectives

1. Transparency: Providing updated, accurate and reliable real estate information.
2. Integration: Establishing a central and reliable national source of real estate information.
3. Investment: Encouraging investment by providing real estate information.
4. Technology: Employing artificial intelligence techniques and real estate technology.
5. Sustainability: a sustainable real estate sector that supports other economical sectors.

Aqari project will achieve a qualitative leap in the Bahrain's real estate sector, to support the strategic objectives of the Kingdom and enhance its position as a pioneer hub in the region.

Participating Bodies & Partnerships

Aqari project witnessed a unique cooperation among various governmental agencies and private companies. This has enriched the platform with a variety of valuable information, making it the first destination for those who are seeking precise data about the real estate market in Bahrain. Since its launch, the platform was based on multi-parties' cooperation between government bodies and private enterprises to achieve a unified vision towards development of the real estate sector. This cooperation reflects commitments of all these bodies to support the development and sustainability of the real estate market in the Kingdom of Bahrain.

The Most Significance Features of Partnership in this Ambitious Project

1. Real Estate Regulatory Authority (RERA): It is the main engine behind the platform in addition to its duties of regulating and developing the real estate sector and making available a stable and sustainable investment environment.
2. Survey and Land Registration Bureau; Provides the platform with accurate date regarding real estate and survey registration, and thus ensuring transparency in dealings.

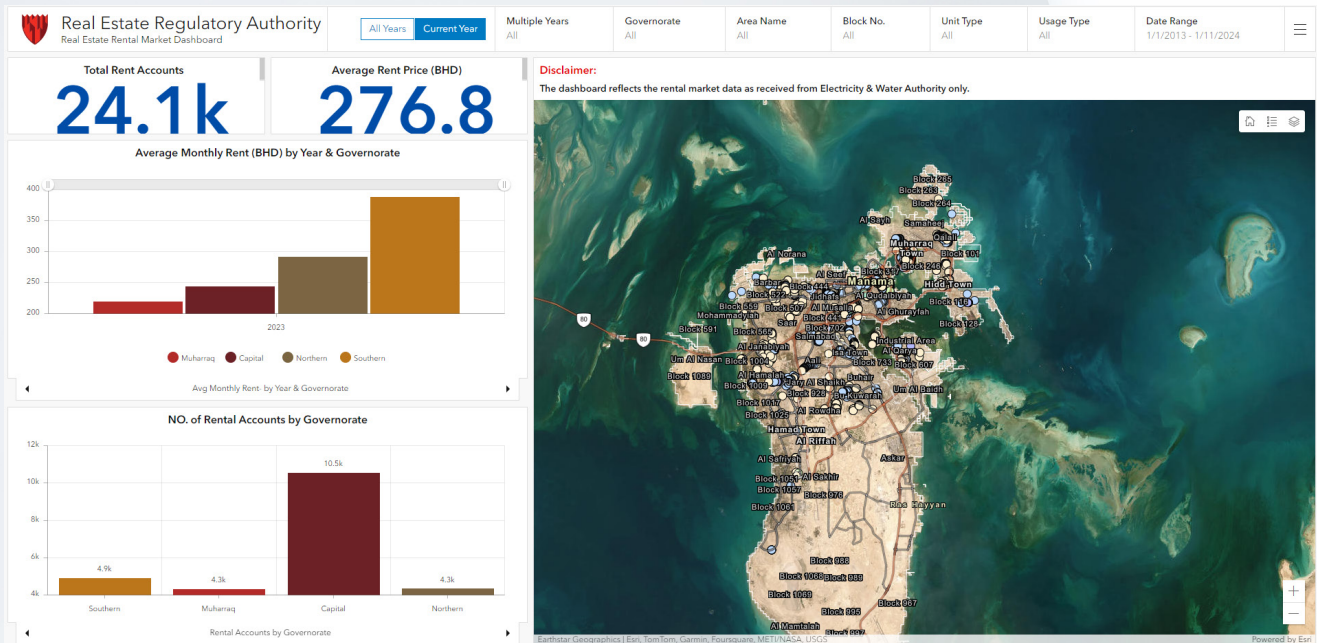

3. Information and eGovernment Authority (IGA): Provides technological infrastructure and digital support, and ensuring availability of real estate data and statistics in a highly professional manner.

4. Electricity & Water Authority (EWA): Contributes with information on the electricity and water services and infrastructure real estate information.

5. Ministry of Housing & Urban Planning: Provides the platform with information on housing projects and urban planning, and contributes in drawing a comprehensive image of the residential market.

6. Ministry of Industry & Commerce: provides information on the commercial and industrial activities related to the real estate sector.

7. Ministry of Works: It provides data on the infrastructure and urbanization projects, giving a clear picture of the current and future developments.

8. Ministry of Municipalities Affairs and Agriculture: Provides information on municipalities affairs and agricultural lands and their effects on the real estate sector.

9. Urban Planning and Development Authority (UPDA): Seeks to provide a comprehensive vision on urban planning and development and its impacts on the market.

10. Building Permits System (BENYAT): Provides the platform with information on building permits and as such it helps in understanding the trends of building and development.

11. Housing Bank: Contributes with information on residential financing and residential projects and supports a comprehensive and the complete understanding of the market.

12. Central Bank of Bahrain: Presents a regulatory and financial framework that supports the stability and development of the real estate market.

13. Bahrain Tourism and Exhibitions Authority: Provides information on tourism and exhibitions which helps in understanding their effects on the real estate market.

The Information Provided by the Platform

Aqari provides various important information that serve the real estate market and the dealers, most importantly:

- Details of Real Estate Transactions: This cover the details of real estate deals including information on amounts and volume of deals and market trends etc.

- Details of Hotels Sector: The platform provides detailed information on the hotels sector,

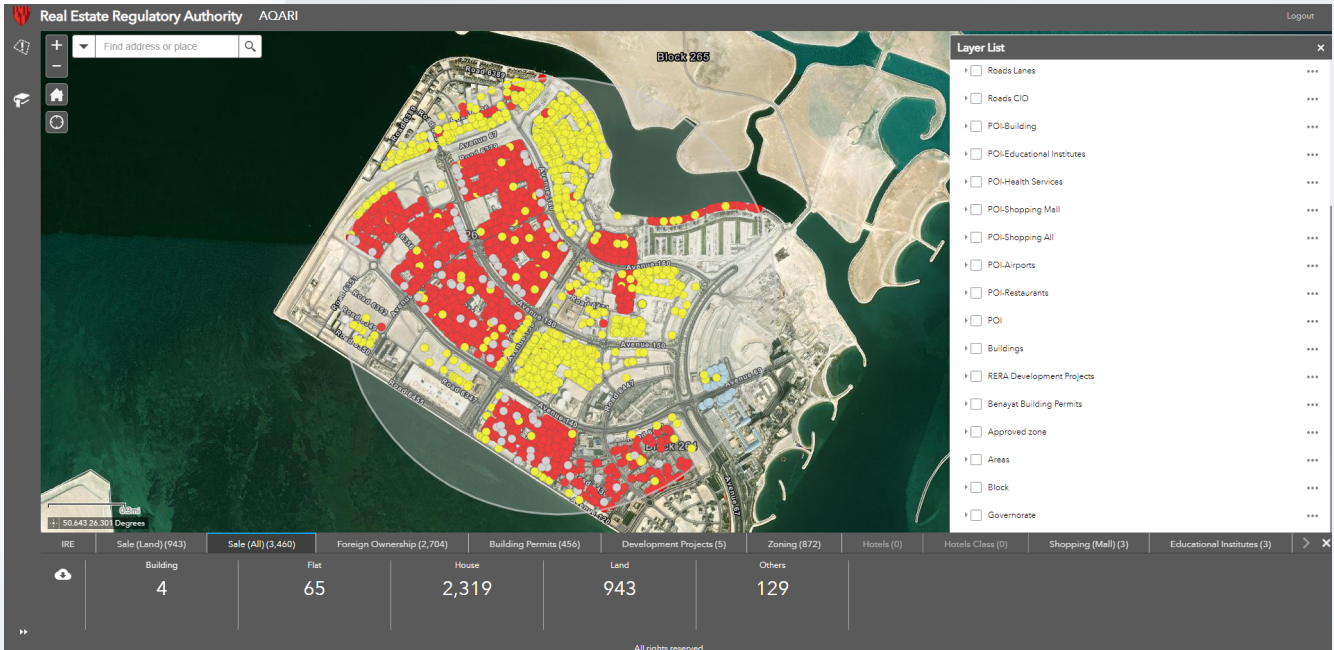

occupancy rates, average room rates and market trends.

- Information on Urban Classifications: The platform provides classification of urban zones which may include residential, commercial or industrial purposes etc.
- Infrastructure information: Includes information on the current or planned infrastructure projects.
- Details of Real Estate and Development Projects (Selling on paper): The platform provides information on the real estate projects, the units of which are sold prior to actual construction, which enables the investors to learn about the projects under development and available for investment.
- Details of Building Permits: Includes information on the permits that have been issued for the new projects and this present information on the construction activities in various areas.
- Leased and Vacant Properties: The platform provides information on the properties that are available for rent and those that are not yet rented, and thus providing an overview of the rental market status.

“Aqari Platform is a vital tool for investors, developers and real estate brokers, helping in creating a comprehensive overview of the real

estate market which helps in taking more effective and efficient decisions”.

The Techniques Used

Aqari platform uses the latest know how and technologies available. It depends on a pool of information to gather information from various sources and analyze them, by using cloud computing to guarantee easy access and information security. Artificial intelligence is also used to ensure advanced and dedicated user experience. This reflects creativity in dealing in real estate transactions.

Role of GIS in Aqari Platform

- Spatial Analysis: GIS allows the possibility of conducting complex spatial analysis, helping in understanding geographical relations and patterns within the real estate market.
- Data Visualization: The GIS tools provides solid ways to visualize the real estate data such as the interactive maps and 3D visualization in a manner that facilitates absorption of data by the users and thus helping them to take their decisions.
- Planning and Development Support: The spatial

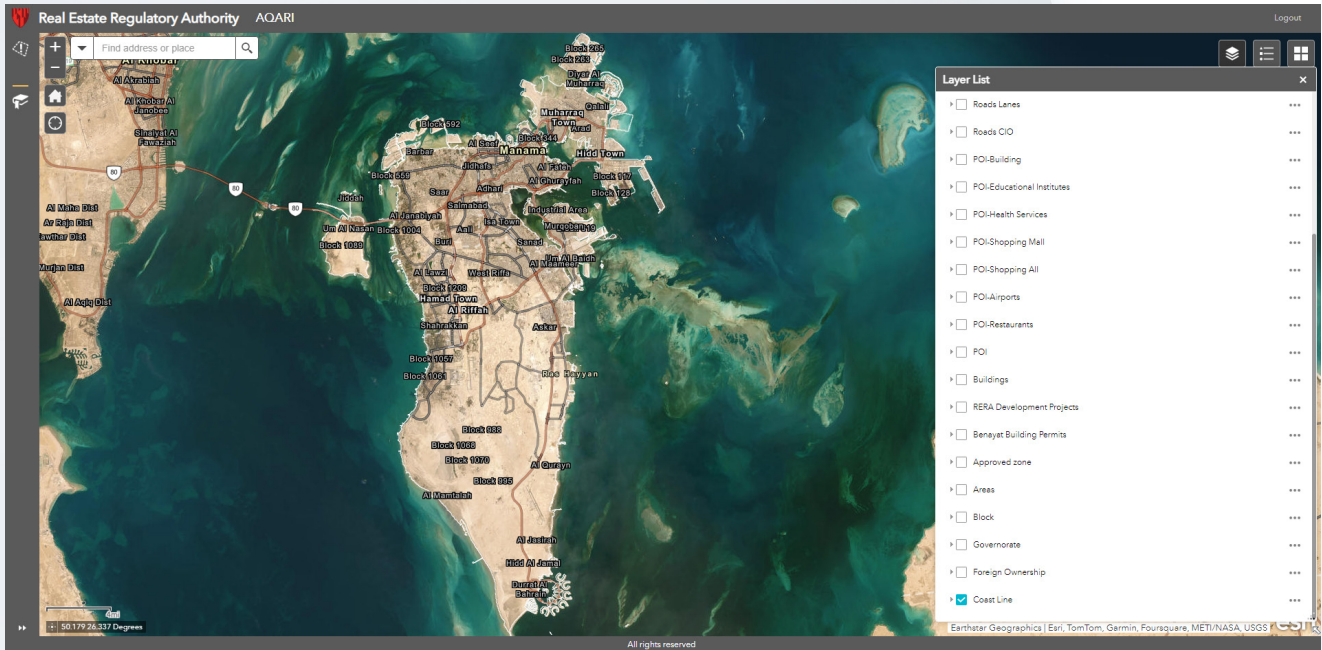

data may be used to support urban planning and property development, through identifying opportunities and challenges within specific geographical areas.

Role of Information Pool:

- Central Storage: The information pool shall act as a central storage for collecting large and various real estate data from a variety of resources in a unified environment.
- Analyzing large data: The information pool allows analysis of data in huge volumes, and as such it helps in discovering new visions and patterns that are not clear in the real estate market.
- Flexibility and Expandability: The information pool permits substantial flexibility in storing and data processing of different types and pattern. This supports any future expansion of the platform.

Role of AI

Artificial Intelligence plays a pivotal role within Aqari platform through enhancing and analyzing capabilities and data processing. This presents a rich and accurate user experience in respect of real estate information. It is one of main features of AI, represented in its ability to link and integrate

various information resources in order to update information efficiently and periodically, including the use of satellite images to ensure obtaining updated information that reflects the realistic changes on the ground. This technology is considered a revolution in the filed of data analysis. It helps in minimizing human errors and presents complex reliable analysis that assists in taking more clear and speedy decisions, and thus increasing efficiency, reducing time and efforts that are required in classical analysis.

Due to these features, Aqari stands as a model of innovation and efficiency in the filed of real estate information, providing a valuable tool to the investors, developers, researchers and all the concerned parties in the real estate sector in the Kingdom of Bahrain.

Subscription and Access to Information

Aqari's subscription system is flexible and meets various needs of users, from amongst individuals and major companies. This allow everybody to benefit from the valuable data and analysis that are provided through the platform. The normal subscription in Aqari Platform provides an opportunity to have an access to an overview of the real estate



The introductory workshop organized by the Bahrain Society of Engineers at its headquarters in Juffair on the evening of Tuesday, March 5, 2024, on the Real Estate Information Bank platform “Aqari”, which was presented by His Excellency Sheikh Mohammed bin Khalifa Al Khalifa, CEO of the Real Estate Regulatory Authority, and was attended by a remarkable number of concerned officials in the two sectors. Public and private.

deals, with a feature of “Map Viewer” that allows browsing real estate maps and data easily. It also includes information on the projects in the real estate sector, trading, details of building permits, classifications of urban planning in addition to real estate’s professionals list. Subscription in Aqari is suitable for individuals and companies that aim to obtain comprehensive information. The advanced membership allows the users to benefit from all the features of normal subscription in addition to “Map Viewers” feature which allows obtaining accurate and detailed analysis about tourism, local hotels and infrastructure, built and unbuilt lands in addition to information on the occupancy rates. This subscription is ideal for major companies that require in-depth data to enhance their studies and to efficiently take strategic decisions.

Towards a Promising Future

Aqari is an inspiring success story that shows how cooperation and innovation can enhance a vital sector like the real estate sector, and thus contributing in achieving a sustainable economic

development and foster the position of Bahrain as a pioneering real estate hub in the region.

Aqari continues in its progress while committed to excellence and innovation, so it promises to attain further achievements in the future.

Since its early beginnings in 2019, the National Real Estate Data Bank (Aqari) marked a milestone in the history of real estate sector in the Kingdom and registered an inspiring success story, thanks to its strategic directions and its reliance on the latest know how in the filed of AI and cloud computing. Aqari is looking forward to achieving a bright future and to enhance clients experience through providing them with value-added information. Undoubtedly, its role shall expand to include stimulating innovation and enhance economical development in the Kingdom, driven by a unique spirit of Bahraini team.

You may visit the platform through Aqari.rera.gov.bh for subscription of learning further available information or communicating with the work team.

course on Analog Electronic Circuits that is normally taken as part of an undergraduate program in Electrical, Electronic, communications or other related engineering programs. It can be utilized for a second course on Electronics with the first two chapters acting as a solid and complete review to help the students find relevant information in one place. Since the book starts with device fundamentals, it can be also adopted for programs that require a single course on electronics in their curriculum.

The book does not compete with established books but rather complements them by providing the students with an easy, short, and solid start. Students can then consult their textbooks and references for further information. This is why no problems are provided here, so students can use their own text for exercises.

Book coverage

This book deals with the theory and applications of BJT, MOSFET and Op amp, as active devices. It has nine chapters starting with bipolar junction transistors and ending with feedback circuits. The detailed coverage of the book is provided under the contents.

Key features

- Concentrates on the underlying principles and the logic behind the topics being presented.
- Presents important and fundamental topics in a simple way.
- Theory and applications are presented in a compact form but with all necessary information needed for students' understanding.
- The examples given show all solutions' steps.
- The theory is discussed through examples.
- More than eighty examples are provided, some of them are design cases.
- Students will be able to understand the operation

of electronic circuits and small systems.

- They will also be able to design simple circuits.
- A modified and simplified technique for analyzing 'multistage amplifier' is introduced.
- A companion website 'www.electronic-circuits.com' gives extra resources for students and faculty.
- Mathcad programs used in the book are available for download from the website.
- An inexpensive book that is affordable by students around the world.

Author... profile:

Dr. Abdul Imam Al Sammak

Dr. A. Imam Al-Sammak is a retired Associate from the University of Bahrain where he has been a faculty member for 39 years.

Al-Sammak received his M.Sc. in Digital Communications from the University of Kent, UK in 1981 and his Ph.D. in Communications from Manchester University, U.K in 1987.

During his tenure at the UOB, Dr. Al-Sammak was instrumental in developing the Electrical and Electronic Engineering programs and laboratories where he has served as the chairman of the Department for four years.

He has taught various subjects in the fields of Communications, Electric circuits, and Electronics. He has published more than 40 research papers and holds three patents. Dr Al-Sammak served as a reviewer for international journals and conferences (including IET Electronics Letters, IET communications and IEEE PACRIM conference).

He has been a visiting scholar at University of Victoria, Canada during summer sessions of 1998, 2001 and 2004, and visiting scientist at Purdue University summer 2008, USA.

Dr. Al-Sammak is a chartered engineer, member of IET (UK) and a life member of the Bahrain Society of Engineers where he served as a board member for two years. Presently, Dr. Al-Sammak is the chairman of IET Bahrain Local Network.



Eng. Khalid Qarooni

Engineer with COPA-DATA

From Oil to Sunshine: Battery Energy Storage Lights the Way

The Middle East is transitioning towards renewable energy. However, the variability of solar and wind power poses a challenge to grid stability. To bridge the gap between intermittent renewable energy generation and continuous electricity demand, battery energy storage systems (BESS) offer a compelling solution.

The Middle East and renewable energy potential

The Middle East region has immense potential for renewable energy generation, particularly solar power. Sun-rich countries such as Saudi Arabia, the United Arab Emirates (UAE), and Qatar have embarked on ambitious renewable energy projects to diversify their energy mix and reduce dependence on fossil fuels. The transition to renewables is highlighted by the Middle East's active engagement in global climate action, such as hosting the UN Climate Change Conference COP23 in the United Arab Emirates in 2023 or Saudi Arabia's construction of NEOM, a city that is to be powered by 100% renewable energy sources.

The Energy Information Agency foresees an estimated 15 - 25 GW from each of the three main renewable energy sources – wind, photovoltaics, and concentrated solar power – in the Middle East by 2035¹. Saudi Arabia has set itself an ambitious goal of achieving 50 percent green energy by 2030, having secured the highest value of renewable energy contracts awarded between 2012 and 2022. Following closely are Egypt and the UAE².

To achieve these goals, the region must answer the challenge that the intermittent nature of solar and wind power poses for grid operators in maintaining stable and reliable electricity supply.

The role of BESS in the Middle East

Battery energy storage systems play a vital role in unlocking the true potential of renewable energy sources in the Middle East. By capturing excess energy during periods of high generation and storing it for later use, BESS helps mitigate the intermittency challenge, ensuring a consistent power supply and grid stability.

According to a report by APICORP, the Middle East and North Africa (MENA) region is expected to see a significant increase in the deployment of battery energy storage systems in the coming years. Countries in the MENA region will need to rapidly deploy battery energy storage systems in their power grids if they are to meet their national renewable energy targets³.

According to reports, there are 30 BESS projects planned in MENA between 2021 and 2025 with a total capacity/energy of 653 MW/3,382 MWh. Out of these, 24 projects are dedicated to integrating variable renewable energy (VRE) and enhancing grid stability. The share of batteries out of the total energy storage landscape in MENA is expected to jump from the current 7% to 45% by 2025⁴.

1 - <https://www.sciencedirect.com/science/article/pii/S2666790823000046>.

2 - <https://www.statista.com/topics/11686/renewable-energy-in-mena/>.

3 - <https://www.saurenergy.me/middle-east-to-achieve-92-of-regions-renewable-energy-targets-by-2030-report/>.

4 - <https://www.apicorp.org/news/apicorp-energy-storage-solutions-key-to-achieving-menas-ambitious-renewable-targets>.

Advantages of Battery Energy Storage Systems

The use of BESS aligns with the region's sustainability objectives. In 2022, more than 5 billion dollars were invested in BESS worldwide, highlighting the growing importance of this technology. The significant investment reflects an acknowledgment that BESS is a crucial tool in minimizing the risks associated with energy bottlenecks and ensuring a smooth transition to renewable energy in the Middle East. Moreover, the global BESS market is expected to reach between 120 billion and 150 billion dollars by 2030, indicating the promising future prospects and potential growth of this industry worldwide.

Let's take a closer look at the significant benefits that BESS are contributing to the transition to renewable energy.

1. **Renewable Integration:** BESS facilitates the seamless integration of renewable energy sources into the power grids. By storing excess energy during peak solar production periods, battery systems bridge the gap during periods of low or no solar power generation, optimizing the use of renewable resources and reducing reliance on fossil fuel-based generation.
2. **Grid Stabilization:** The Middle East's electrical grids will benefit significantly from BESS in terms of frequency and voltage regulation. The integration of battery systems helps absorb variations caused by intermittent renewable energy generation, enabling a more stable grid and reducing reliance on conventional backup generation.
3. **Demand Management:** Battery storage is a game-changer for managing electricity demand. Instead of relying on expensive fossil fuel-powered peaker plants during high-demand times, stored energy can step in, cutting costs and reducing carbon emissions. This not only enhances grid reliability but also aligns with the region's sustainability goals by minimizing carbon emissions. In addition, storing energy also avoids potential energy bottlenecks.
4. **Energy Independence:** Battery energy storage

5 - <https://www.mckinsey.com/industries/automotive-and-assembly/our-insights/enabling-renewable-energy-with-battery-energy-storage-systems>.

6 - Innovations in Energy Storage Systems Market: A Road map to a Sustainable Energy Future

7 - UAE should deploy 300MW BESS capacity by 2026, says utility (energy-storage.news).

8 - <https://www.energy-storage.news/sungrow-awarded-600mwh-bess-contract-for-saudi-arabias-smart-city-neom/>

systems also contribute to enhancing energy independence in the MENA region. Governments in the region are increasingly recognizing the importance of diversifying their energy sources and reducing their dependence on conventional fossil fuels. BESS enables countries in the region to diversify their energy sources and promote renewable energy utilization, supporting their long-term energy security goals.

Challenges and future outlook

While the adoption of battery energy storage systems in the Middle East is promising, several challenges need to be addressed for widespread deployment. The BESS market has significant potential, but it faces key challenges for sustained growth and success. A notable challenge is the cost and economics of BESS deployment. Despite falling prices, a significant up-front investment remains a barrier, so a thorough cost-benefit assessment against alternatives such as natural gas peakers is needed for wider deployment.

In addition, BESS faces technological and performance challenges, including limited energy density, degradation over time and safety concerns. Addressing these issues is essential to improve the overall performance and reliability of battery energy storage systems. The lack of standardized regulations and policies specific to energy storage is another barrier to market growth. Clear frameworks covering grid interconnection, safety standards and planning and compliance procedures are essential to facilitate the widespread and efficient deployment of BESS. Furthermore, integrating BESS into existing electricity grids presents technical challenges that may require upgrades or modifications to the grid infrastructure. Efficient grid integration is crucial for the successful deployment of battery energy storage systems.

Despite these challenges, recent reports indicate that the UAE has committed to deploying 300MW/300MWh of battery energy storage capacity by 2026. Similarly, a leading energy storage solutions provider has secured a contract to supply battery energy storage systems to Saudi Arabia's NEOM smart city. The contract covers the supply of 600MWh of BESS, highlighting the significant scale of the project. These developments underline the strategic importance of energy storage solutions in the Middle East, signaling a commitment to sustainable and resilient energy infrastructure.

Biohydrogen from Microalgae: Sustainable Future for Clean Energy Demand



Eng. Dr. S. M. Zakir Hossain

Associate Professor,
Department of Chemical
Engineering, University of
Bahrain, Bahrain.

Introduction:

The growing global population has increased the demand for energy, leading to a greater emphasis on researching renewable energy resources. Fossil fuels, the current mainstay of global energy supply, are non-renewable and environmentally detrimental. The fossil fuel supply is expected to run out in fewer than 50 years. Hence, these fuels may someday become scarce. In this context, biohydrogen or hydrogen fuel has emerged to replace conventional fossil fuel as a promising renewable and green energy due to its non-polluting nature and high energy efficiency. Hydrogen is an energy carrier and can deliver or store a tremendous amount of energy. It is the most abundant element in the universe and holds the richest energy per unit mass (120 MJ/kg). Microalgae have gained attention as an attractive feedstock for generating hydrogen. Hydrogen, derived from microalgae, holds great potential as a clean and sustainable alternative to fossil fuels, contributing to low carbon dioxide emissions and reduced environmental pollution. Thus, hydrogen is now considered the next generation of clean fuel.

Hydrogen source and production method

Currently, the major ingredient in producing hydrogen is dependent on non-renewable (e.g., natural gas, coal, and petroleum) and renewable (e.g., biomass, water) sources. Various processes are used to produce hydrogen, and extensive research is being done to optimize these processes, as shown in Figure 1. Producing hydrogen from fossil fuels is costly and not still feasible for the environment. Producing hydrogen from water needs a huge amount of energy. Hence, there is a strong imperative to investigate renewable energy resources, particularly biomass, that can meet future demands. In this regard, microalgae biomass is rich in specialized compounds like lipids and carbohydrates, which can be converted easily into biohydrogen.

Mechanism of Biohydrogen Production

Biohydrogen production from microalgae involves mainly thermochemical and biological processes (see Fig 1). However, the thermochemical processes (e.g.,

gasification, pyrolysis, combustion) are tedious and costly. Additionally, carbon dioxide emissions may occur during hydrogen production, which negatively impacts the Earth's ecosystem and contributes to global warming. On the other hand, biological processes such as fermentation (photo and dark) and photolysis (direct and indirect) are cost-effective processes. These technologies have the same principle which is splitting the water into hydrogen and oxygen with two different mechanisms. The main feed components are water, CO₂, some nutrients, and light, except for the dark fermentation process. Figure 2 represents the photolysis and fermentation methods and their classifications for biohydrogen production.

Pros and cons

The advantages of using microalgae for biohydrogen production are the fact that their carbohydrate composition and their simple structures make them excellent candidates to be used as substrates for hydrogen production because the oxidization of carbohydrates can enhance hydrogen production.

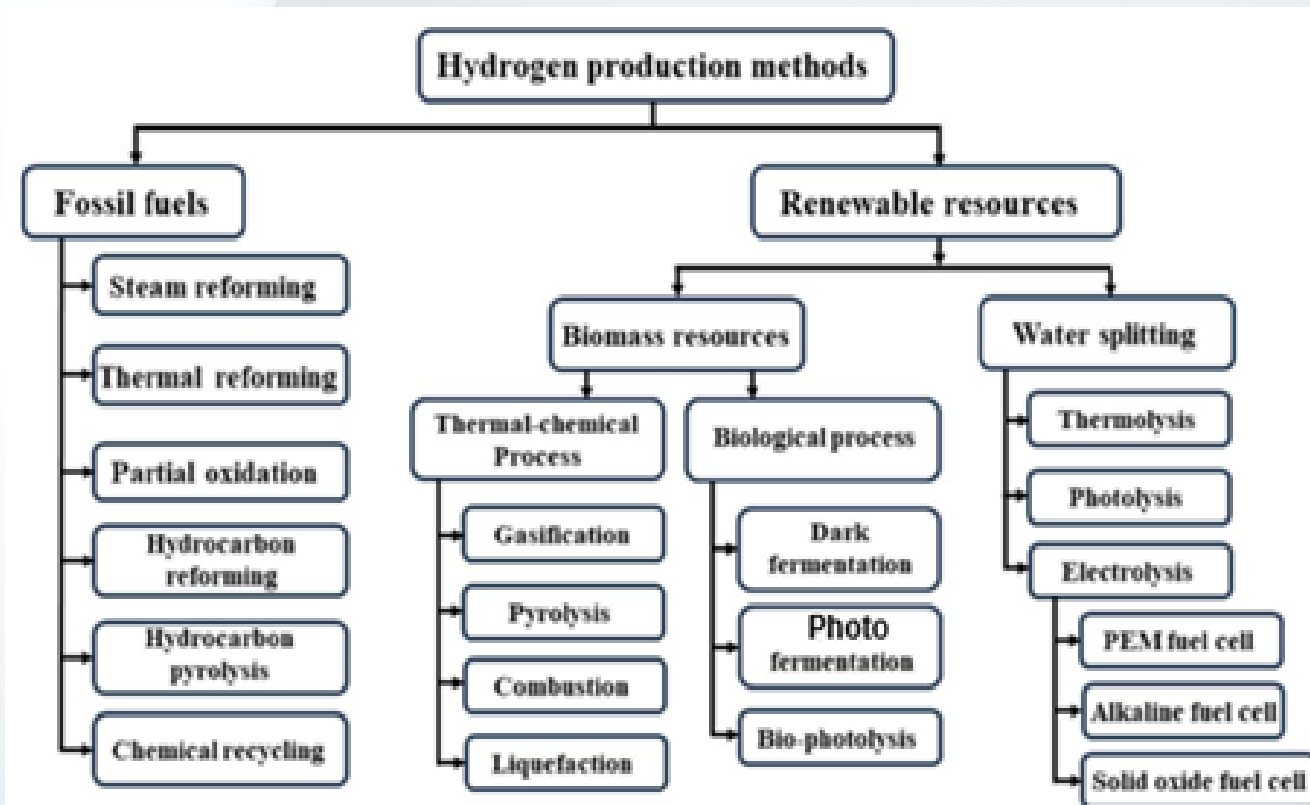

Figure 1: Hydrogen production processes

Moreover, the microalgal growth rate is very high. They can double the growth in short periods of time, they have the ability to fix CO_2 , and their cultivation is environmentally friendly.

On the other hand, using microalgae for biohydrogen production is disadvantageous because the biomass is relatively small and difficult to produce at a large scale. Another disadvantage is the inability of light to penetrate dense cultures. Finally, harvesting microalgae is a bit costly since microalgae need to be dried after being harvested from water environments. These disadvantages need to be overcome by developing technologies.

Conclusions

Biohydrogen from microalgae is a potential alternative resource for hydrogen production.

It is a clean technology that consumes CO_2 and is a renewable, cost-effective process.

Such alternative renewable and clean sources of hydrogen are always needed to meet the increasing global energy demand for the future and simultaneously suppress CO_2 emissions.

Figure 2: The main methodologies for producing hydrogen from microalgae

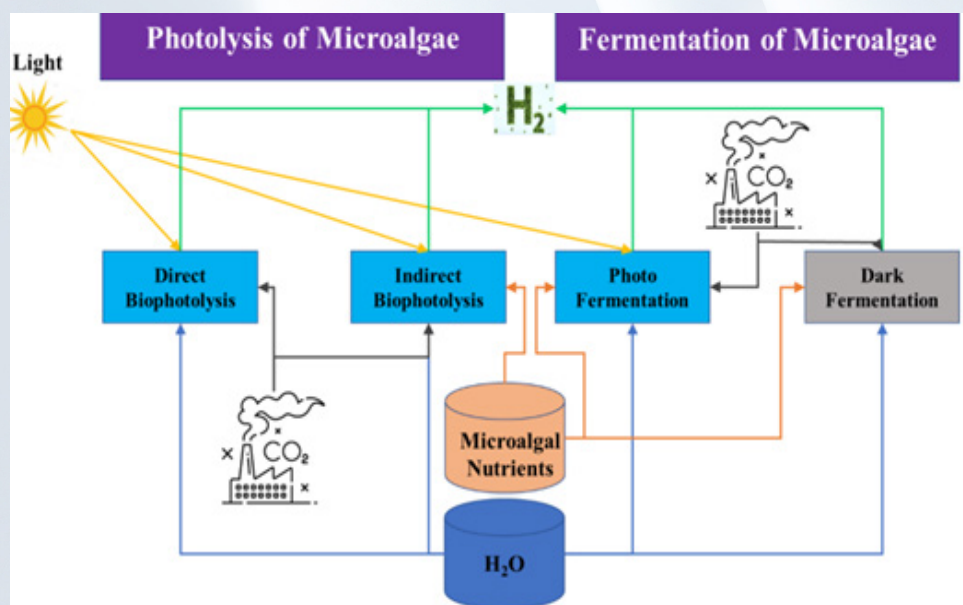



Drone (Octocopter)

Project Team: Ahmed Habib Haji, Husain Ali Abdulla, and Saleh Khaled Buanaq
Supervisor: Dr. Mohammed Al-Khaledi, Department of Electrical and Electronics Engineering, University of Bahrain

This project on the design and implementation of an octocopter drone with a unique structural configuration, featuring eight arms, each divided into two sets of four arms of different lengths.

Three students worked on the project Ahmed Habib Jassim Haji, Husain Ali Abdulla Isa and Saleh Khaled Saleh Buanaq under supervision of Dr. Mohammed Al-Khaledi from the department of Electrical and Electronics Engineering at University of Bahrain. The motivation behind this design choice is to optimize the drone's stability and maneuverability, leveraging the benefits of both longer and shorter arms. The drone is equipped with eight motors, with adjacent motors connected in parallel to overcome the limitation of the Arduino Uno's six PMW pins "PWM (Pulse Width Modulation)". Each motor is controlled by its dedicated Electronic Speed Controller (ESC).

The primary challenge addressed in this project was the creation of stable and maneuverable octocopter drone, distinctive in its eight-arm configuration. The locally customized standard drone frame served as a practical and adaptable solution, showcasing the team's resourcefulness



in hardware assembly. The integration of Proportional-Integral-Derivative (PID) control system successfully achieved auto-leveling functionality, contributing to stable flight performance.

The main results of the project underscore the successful realization of a functional octocopter drone. The hardware assembly demonstrated adaptability, offering a cost-effective solution while overcoming challenges posed by global disruptions.

The Proportional-Integral-Derivative control system implementation and flight tests validated the drone's stability, through recognizing the ongoing need for Proportional-Integral-Derivative tuning and sensor calibration.

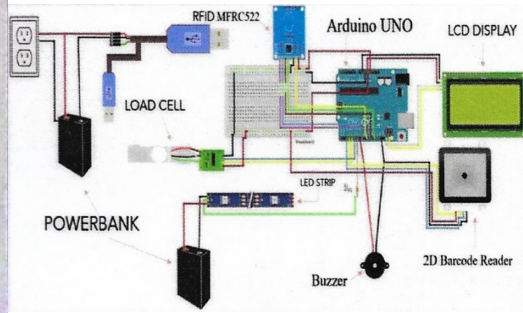
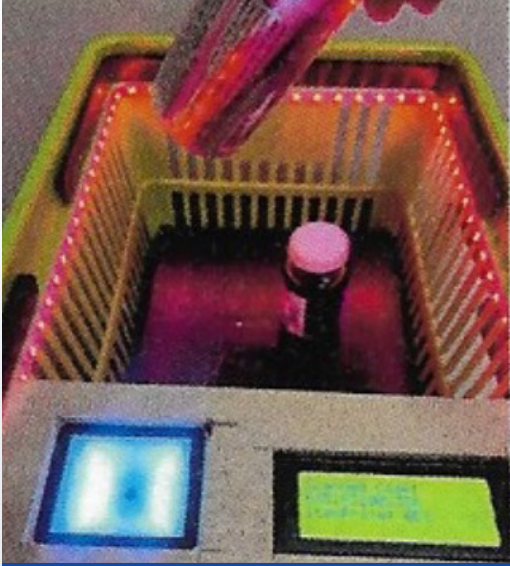

Smart Shopping Basket

Project Team: Abdulla Yousif Hassan, Ammar A. Nabi Salman and Ayoob Jaffar Ebrahim
Supervisor: Dr. Ebrahim AbdulRahman, Department of Electrical and Electronics Engineering, University of Bahrain

Three students worked on the project Abdulla Yousif Hassan, Ammar A. Nabi Salman and Ayoob Jaffar Ebrahim under supervision of Dr. Ebrahim AbdulRahman from the department of Electrical and Electronics Engineering at University of Bahrain. The Smart Shopping Basket features a contactless self-checking system seamlessly embedded within its design. This intelligent system not only expedites the checkout process, significantly reducing waiting times, but also improves the overall shopping experience. Complementing this, a precision scale is incorporated to ensure security by comparing the weight of items in the basket with their scanned counterparts, mitigating the risk of theft.

As seen by the researchers, blue light indicates everything is safe. After we scan the item, the total weight increases with an indication red light to inform us that you need to put the item you scanned. If we put the item, the system compares the calculated weight to ensure that we put the right item inside the basket. After we finish with putting the desired item, we RFID detect the card by NFC technology and the light turn green to indicate that the item inside was

paid, after we remove the item from the basket the total weight become zero and the basket is ready to be used again.

In conclusion, the challenge of managing a constrained budget through this project was effectively navigated through the strategic use of Arduino and other cost-friendly components. The decision to employ an Arduino-based system not only proved to be an economically prudent choice but also showcased the versatility and efficiency that this platform offers. By carefully selecting budget-friendly components, the project successfully maintained a balance between functionality and financial constraints. This logical approach not only enabled the completion of the smart basket project within but also emphasized the significance of thoughtful decision-making and resourcefulness in addressing financial limitation. In essence, the utilization of Arduino and cost-effective components played a key role in ensuring the project's success while highlighting the importance of practical solutions in the face of budgetary challenges

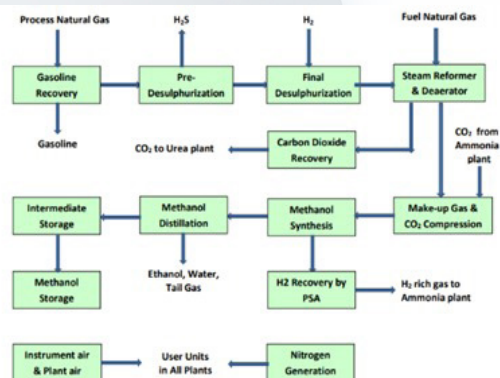
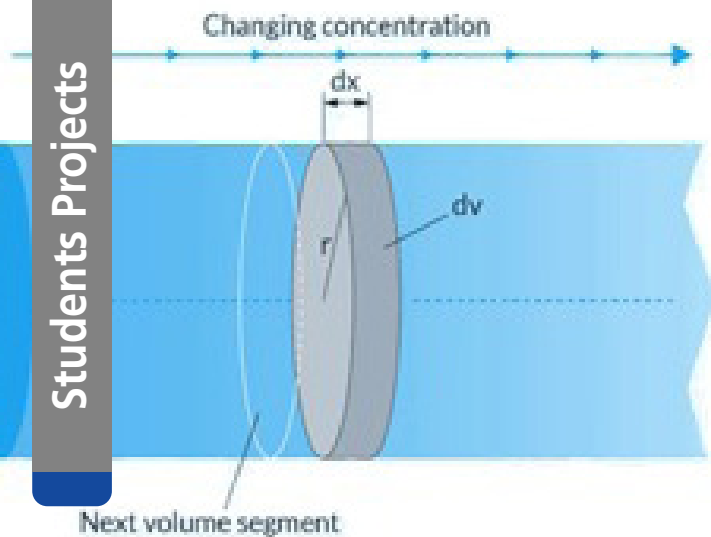

Simulation, Optimization, and Control of Methanol Production using Four Different Configurations

Project Team: Jenan Mohamed Mahmood, and Yomna Moosa Ayyad
 Supervisor: Dr. Bassam Alhamad, Department of Chemical Engineering,
 University of Bahrain

This project focuses on the improvement of methanol production processes and the promotion of a sustainable, clean environment through the utilization of renewable energy sources. Both students Jenan Mohamed Mahmood and Yomna Moosa Ayyad worked on this project under the supervision of Dr. Bassam Alhamad, department of Chemical Engineering at University of Bahrain. Methanol, known for emitting minimal pollutants upon ignition and consuming carbon dioxide (CO₂) during production, making it a viable alternative to conventional fossil fuels and contributing to the reduction of greenhouse gas emissions. The study employs a digital twin methodology, using Aspen HYSYS software to design and simulate various configurations of methanol synthesis units.

These configurations are tailored to specific constraints related to reactor types (Equilibrium Reactor or Plug Flow Reactor, PFR) and cooling techniques (Indirect Cooling or Direct Quenching). The objective is to identify the optimal configuration that maximizes

methanol production yield, while considering temperature profiles, production quantities, and considerations of profitability. Simulation results indicate that Configuration 4 that utilizes five PFRs with Direct Quenching, achieves a production yield of 1770.66 kmol/hr, in line with industry standards. Through case studies utilizing the software's "Case Study" feature, different scenarios are explored, and relationships between independent and dependent variables are established. Significant variables such as syngas temperature and pressure are used to optimize the profitability objective function. The results demonstrate a maximized profit of \$4.8 million/year with a production yield of 1787.04 kmol/hr when the syngas temperature increases by approximately 30°C, up to 233.85°C. The robustness of the control configuration (PID controllers) is evaluated through dynamic mode testing, setpoint tracking test, and disturbance rejection test, indicating stability, adaptability to real-time changes, and efficient methanol production.



In the presence of

H.E. Shaikh Khalid bin Abdulla Al Khalifa
Deputy Prime Minister
Kingdom of Bahrain



26th GULF ENGINEERING FORUM

ENERGY MANAGEMENT

CONFERENCE & EXHIBITION 2025

“Energy Transition Challenges”

11 - 13 FEBRUARY 2025

WWW.GEF26.BH

IMPORTANT DATES

Abstract Submission
1 July 2024

Notification of Abstract Acceptance
1 August 2024

Presentation Submission
1 November 2024

Notification of Presentation Acceptance
1 December 2024

Final Presentation Submission
1 January 2025

Conference Date
11-13 February 2025

Abstract Submission Form

26th Gulf Engineering Forum

11-13 February, 2025
Gulf Hotel, Kingdom of Bahrain

Please complete in BLOCK letters.
Complete a separate form for each applicant.

Prof./Dr./ Mr./ Mrs./Miss: _____

Job Title: _____

Organization: _____

Department: _____

Address: _____

City: _____

Country: _____

Postal Code: _____

Telephone: _____

Fax: _____

Mobile: _____

Email: _____

I intend to present a paper and will submit a 400- word abstract inclusive of the title, objectives, authors names and related topic.

Proposed Title is: _____

Please mail or fax this form along with the abstract to the following address:

Forum Secretariat, Bahrain Society of Engineers, P.O. Box 835, Manama, Kingdom of Bahrain Tel: +973 17810734 or
email to : conference.coordinator@bse.bh



Scan for Registration Form

Organized by



Supported by

